

Note

Simulation of Thermoluminescence and Thermally Stimulated Currents

The studies of thermally stimulated processes, like thermoluminescence (TL) and thermally stimulated conductivity (TSC), in different solids yield information about the different traps in them. Based on a model for recombination of trapped electrons and holes via the conduction band, these processes are governed by the equations given by Halperin and Braner [1]:

$$- dm/dt = Amn_c, \tag{1}$$

$$- dn/dt = Sn \exp(-E/kT) - B(N - n) n_c, \tag{2}$$

$$dn_c/dt = dm/dt - dn/dt, \tag{3}$$

where N is the concentration of traps, m is the concentration of holes in recombination centers, n is the concentration of electrons in traps, n_c is the concentration of free electrons in the conduction band, t is the time, A is the recombination probability, B is the retrapping probability, S is the preexponential factor, and E is the

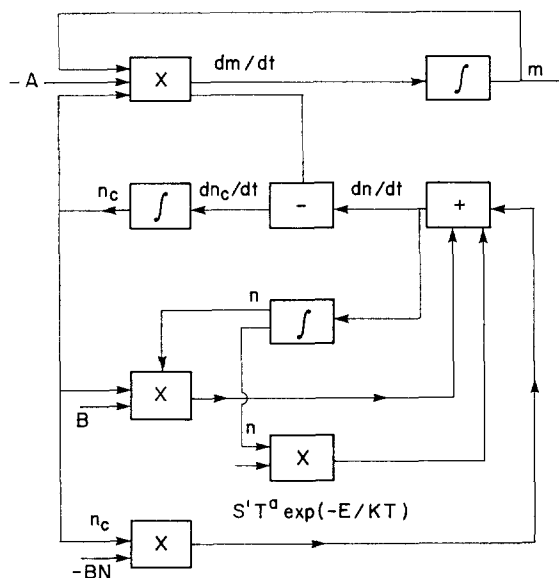

FIG. 1. Schematic of simulation.

TABLE I

No.	m_0 (cm^{-2})	n_0 (cm^{-3})	n_{e0} (cm^{-3})	N (cm^{-3})	A ($\text{cm}^3\text{sec}^{-1}$)	B ($\text{cm}^3\text{sec}^{-1}$)	a	S ($\text{sec}^{-1}\text{K}^{-a}$)	E (eV)	$T_m(^{\circ}\text{K})$ CSMP	$T_m(^{\circ}\text{K})$ (3)	μ_r CSMP	μ_s (3)
(1)	10^7	10^8	8.48	10^{10}	5×10^{-4}	10^{-7}	0	10^{10}	0.316	136.5	136.8	0.305	0.308
							1	8.3×10^7		136.0	—	0.342	—
							2	7×10^8		135.5	—	0.328	—
							-2	1.4×10^{14}		137.5	—	0.320	—
(2)	10^{10}	10^8	9.45	10^{10}	10^{-7}	10^{-7}	0	10^{14}	0.316	112.0	112.1	0.412	0.418
							1	10^{12}		111.5	—	0.437	—
							2	1.2×10^{10}		110.5	—	0.446	—
							-2	8.1×10^{17}		113.0	—	0.387	—
(3)	10^8	10^8	0.79	10^{10}	3×10^{-8}	10^{-7}	0	10^{10}	0.316	149.0	149.1	0.456	0.468
							1	9×10^7		147.5	—	0.467	—
							2	8×10^8		146.0	—	0.486	—
							0	10^{10}	0.316	177.5	177.8	0.528	0.525
(4)	10^8	10^8	4×10^8	10^{10}	10^{-7}	10^{-7}	1	7.1×10^7		176.0	—	0.607	—
							2	0.5×10^8		175.0	—	0.512	—
							-2	1.9×10^{14}		180.5	—	—	—
							0	10^{10}	0.316	177.5	177.8	0.528	0.525

activation energy for the process. Temperature is varied at a linear rate β . Resulting TL intensity is proportional to $|dm/dt|$ and TSC is proportional to n_c .

If $|dn_c/dt| \ll |dn/dt|$ and $n_c \ll n$, (1), (2), and (3) reduce to a much simpler form:

$$I = -\frac{dn}{dt} = Sn \exp\left(\frac{-E}{kT}\right) \frac{Am}{Am + B(N-n)}. \quad (4)$$

The validity of the above assumption has been tested by Kelly *et al.* [2]. Equations (1), (2), and (3) have also been solved without using this assumption, by Shenker and Chen [3]. A modified Runge-Kutta integration procedure was used by them.

In this paper simulation of the glow curves using CSMP (Continuous System Modeling Program) language is reported. The schematics of the simulation is given in Fig. 1. Simple relation of the type $S = S'T^a$ where $a = 0, 1, 2, -2$, is chosen to study the temperature dependence of the preexponential factor. Milnes' fifth-order-predictor-corrector method was used as the integration procedure. Full details of the description of the application of CSMP are given in IBM Users' Manual, "CSMP (360 - A - CX - 16X)."

The results are given in Table I and are compared with those given in [3]. A representative simulated curve is given in Fig. 2. The situation where there are more than one trap can easily be studied through CSMP language making use of what is known as "Integral arrays." Also the derivative of the TL or TSC curve can be obtained easily using the mathematical function DERIV. The compactness of the program and the ease with which it can be applied, enables one to concentrate more on the process simulated than on the process of simulation.

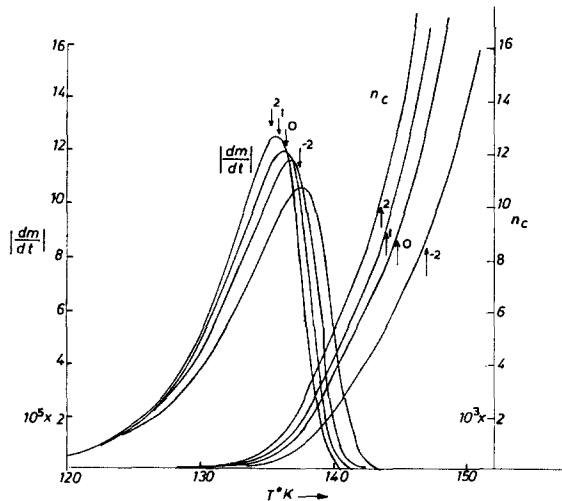

FIG. 2. Calculated values of n_c and $|dm/dt|$. $A = 5 \times 10^{-4} \text{ cm}^3 \text{ sec}^{-1}$, $B = 10^{-7} \text{ cm}^3 \text{ sec}^{-1}$, $m_0 = 10^7 \text{ cm}^{-3}$, $n_0 = 10^8 \text{ cm}^{-3}$, $N = 10^{10} \text{ cm}^{-3}$, $n_{c0} = 8.48 \text{ cm}^{-3}$, $E = 0.316 \text{ eV}$, $S'T^a = 10^{10} \text{ sec}^{-1} \text{ K}^{-a}$, $\beta = 1^\circ \text{ K sec}^{-1}$, $T_0 = 120^\circ \text{ K}$. The values of a are shown by arrowheads.

ACKNOWLEDGMENTS

The author is grateful to C.S.I.R., New Delhi for giving financial assistance in the form of a Junior Research Fellowship.

REFERENCES

1. A. HALPERIN AND A. A. BRANER, *Phys. Rev.* **117** (1960), 408.
2. P. KELLY, M. J. LAUBITZ, AND P. BRÄUNLICH, *Phys. Rev. B* **4** (1971), 2090.
3. D. SHENKER AND R. CHEN, *J. Computational Phys.* **10** (1972), 272.

RECEIVED: April 15, 1976; REVISED: July 19, 1976.

S. HARIDOSS
Department of Physics, I.I.T.
Madras—600036, India